

Enphase Microinverter Model M215



Contact Information

Enphase Energy Inc.
1420 N. McDowell Blvd.
Petaluma, CA 94954

<http://www.enphase.com>
info@enphaseenergy.com
support@enphaseenergy.com

FCC Compliance

This equipment has been tested and found to comply with the limits for a Class B digital device, pursuant to part 15 of the FCC Rules. These limits are designed to provide reasonable protection against harmful interference in a residential installation. This equipment generates, uses and can radiate radio frequency energy and, if not installed and used in accordance with the instructions, may cause harmful interference to radio communications. However, there is no guarantee that interference will not occur in a particular installation. If this equipment does cause harmful interference to radio or television reception, which can be determined by turning the equipment off and on, you are encouraged to try to correct the interference by one or more of the following measures:

- Reorient or relocate the receiving antenna.
- Increase the separation between the equipment and the receiver.
- Connect the equipment into an outlet on a circuit different from that to which the receiver is connected.
- Consult the dealer or an experienced radio/TV technician for help.

Changes or modifications not expressly approved by the party responsible for compliance may void the user's authority to operate the equipment.

Other Information

Product information is subject to change without notice. All trademarks are recognized as the property of their respective owners.

User documentation is updated frequently; Check the Enphase website (<http://www.enphase.com/support>) for the latest information.

For warranty text refer to <http://www.enphase.com/warranty>.

For Enphase patent information refer to <http://enphase.com/company/patents/>.

© 2013 Enphase Energy Inc. All rights reserved.

Table of Contents

Important Safety Information.....	4
Read this First.....	4
Safety Instructions	4
The Enphase Microinverter System.....	5
How the Microinverter Works.....	6
System Monitoring.....	6
Optimal Reliability.....	6
Ease of Design	6
Planning for Microinverter Installation.....	7
Compatibility and Capacity	7
Electrical Compatibility	7
Branch Circuit Capacity.....	7
Parts and Tools Required.....	8
Enphase Equipment	8
Other Items.....	8
Lightning and Surge Suppression.....	8
Enphase Microinverter Installation	9
Step 1: Install the Envoy Communications Gateway	10
Step 2: Measure AC Voltage at the Electrical Utility Connection	11
Step 3: Install the AC Branch Circuit Junction Box	12
Step 4: Position the Enphase Engage Cable	13
Step 5: Attach the Microinverters to the PV Racking	14
Step 6: Ground the System.....	15
Step 7: Dress the Engage Cable	16
Step 8: Connect the Microinverters.....	17
Step 9: Terminate the Unused End of the Engage Cable	18
Step 10: Connect the Engage Cable to AC Junction Box(es).....	19
Step 11: Complete the Installation Map	20
Step 12: Connect the PV Modules.....	20
Commissioning and Operation.....	21
Energize the System.....	21
Build the Virtual Array	21
M215 Operation	21
Troubleshooting	22
Status LED Indications and Error Reporting	22
Startup LED Operation:	22
Post-Startup LED Indications.....	22
GFDI Fault.....	22
Other Faults.....	22
Troubleshoot an Inoperable Microinverter	23
Disconnect a Microinverter from the PV Module.....	25
Install a Replacement Microinverter.....	26
Technical Data	27
Technical Considerations.....	27
M215 Specifications.....	27
Engage Cable Specifications	29
Engage Cable Planning and Ordering Information	30
Selecting Cable Type	30
Connector Spacing Options.....	30
Voltage Types and Conductor Count.....	31
Racking Compatibility	31
Cabling Length Options.....	31
Planning for Cable Lengths and Type	31
Enphase Installation Map.....	33
M215 Dimensions	34
Sample Wiring Diagram: M215, 240 VAC.....	35
Sample Wiring Diagram: M215, 208 VAC.....	36

Important Safety Information

Read this First

This manual contains important instructions for use during installation and maintenance of the Enphase M215 Microinverter™.

To reduce the risk of electrical shock, and to ensure the safe installation and operation of the Enphase® Microinverter, the following safety symbols appear throughout this document to indicate dangerous conditions and important safety instructions.



DANGER! This indicates a hazardous situation, which if not avoided, will result in death or serious injury.



WARNING! This indicates a situation where failure to follow instructions may be a safety hazard or cause equipment malfunction. Use extreme caution and follow instructions carefully.



NOTE: This indicates information particularly important for optimal system operation. Follow instructions closely.

Safety Instructions

- Do not use Enphase equipment in a manner not specified by the manufacturer. Doing so may cause death or injury to persons, or damage to equipment.
- Perform all electrical installations in accordance with all applicable local electrical codes and the National Electrical Code (NEC), ANSI/NFPA 70.
- Be aware that only qualified personnel should install or replace the Enphase® Microinverters and the Engage Cable and accessories.
- Do not attempt to repair the Enphase Microinverter; it contains no user-serviceable parts. If it fails, contact Enphase customer service to obtain an RMA (return merchandise authorization) number and start the replacement process. Tampering with or opening the Enphase Microinverter will void the warranty.
- If the AC cable on the microinverter is damaged or broken, do not install the unit.
- Before installing or using the Enphase Microinverter, read all instructions and cautionary markings in the technical description and on the Enphase® Microinverter System™ and the PV equipment.
- Connect the Enphase Microinverter to the utility grid only after you have completed all installation procedures and after receiving prior approval from the electrical utility company.
- Be aware that the body of the Enphase Microinverter is the heat sink. Under normal operating conditions, the temperature is 15°C above ambient, but under extreme conditions the microinverter can reach a temperature of 80°C (176°F). To reduce risk of burns, use caution when working with microinverters.
- Do NOT disconnect the PV module from the Enphase Microinverter without first removing AC power.
- Be aware that the M215 has field-adjustable voltage and frequency trip points that you may need to set, depending upon local requirements. Only an authorized installer with the permission and following requirements of the local electrical utility should make adjustments.

The Enphase Microinverter System

The Enphase Microinverter® System™ is the world's most technologically advanced inverter system for use in utility-interactive applications. This manual details the safe installation and operation of the Enphase Microinverter.

The three key elements of an Enphase Microinverter System include the:

- Enphase M215 Microinverter
- Enphase Envoy® Communications Gateway™
- Enphase Enlighten® web-based monitoring and analysis software

This integrated system maximizes energy harvest, increases system reliability, and simplifies design, installation and management.



- 1 Enphase Microinverters**
 - are installed beneath each solar module
 - maximize energy harvest
 - send AC power over AC wiring to the load center
 - also send performance data via the AC wiring
- 2 Envoy Communications Gateway**
 - plugs into any AC outlet
 - collects information via the AC wiring
 - transmits data through a standard broadband router to the Internet
 - collects information and transmits it to Enlighten at 5-minute intervals
- 3 Enphase Enlighten Monitoring**
 - provides monitoring and analysis
 - allows performance data to be viewed from any web browser

How the Microinverter Works

The Enphase Microinverter maximizes energy production from your photovoltaic (PV) array. Each Enphase Microinverter is individually connected to one PV module in your array. This unique configuration means that an individual Maximum Peak Power Point Tracker (MPPT) controls each PV module. This ensures that the maximum power available from each PV module is exported to the utility grid regardless of the performance of the other PV modules in the array. That is, although individual PV modules in the array may be affected by shading, soiling, orientation, or PV module mismatch, the Enphase Microinverter ensures top performance for its associated PV module. The result is maximum energy production from your PV system.

System Monitoring

Once you install the Envoy Communications Gateway and provide an Ethernet connection to your broadband router or modem, the Enphase Microinverters automatically begin reporting to the Enphase Enlighten web server. The Enlighten software presents current and historical system performance trends, and it informs you of PV system status.

Optimal Reliability

Microinverter systems are inherently more reliable than traditional inverters. The distributed nature of a microinverter system ensures that there is no single point of system failure in the PV system. Enphase Microinverters are designed to operate at full power at ambient temperatures as high as 65° C (150° F). The microinverter housing is designed for outdoor installation and complies with the NEMA 6 environmental enclosure rating standard:

NEMA 6 rating definition: Indoor or outdoor use primarily to provide a degree of protection against hose-directed water, the entry of water during occasional temporary submersion at a limited depth, and damage from external ice formation.



NOTE: To ensure optimal reliability and to meet warranty requirements, the Enphase Microinverter must be installed according to the instructions in this manual.

Ease of Design

PV systems using Enphase Microinverters are very simple to design and install. You will not need string calculations, and you can install individual PV modules in any combination of PV module quantity, type, age and orientation. You won't need to install cumbersome traditional inverters. Each microinverter quickly mounts on the PV racking, directly beneath each PV module. Low voltage DC wires connect from the PV module directly to the co-located microinverter, eliminating the risk of personnel exposure to dangerously high DC voltage.

Planning for Microinverter Installation

The M215 is compatible with most 60-cell PV modules (to 270W or higher) and installs quickly and easily. It works with either three-phase 208 VAC or single-phase 240 VAC services. The M215 ships with integrated DC and AC cables and connectors. The DC connectors attach to the PV module, while the AC connector attaches directly to the Engage Cable. No additional cabling is needed.

The Engage Cable is available in two connector spacing options and two voltage types to meet varying site requirements. For Engage Cable ordering information, see “Engage Cable Planning and Ordering Information” on page 30.



WARNING: Be aware that installation of this equipment includes risk of electric shock. Normally grounded conductors may be ungrounded and energized when a ground fault is indicated.

Compatibility and Capacity

The Enphase M215 Microinverters are electrically compatible with most 60-cell PV modules. For more information, see “Technical Data” on page 27 of this manual. Refer to the Enphase website (<http://www.enphase.com/support>) for a list of **electrically** compatible PV modules and approved PV racking systems. To ensure **mechanical compatibility**, be sure to order the correct connector type for both microinverter and PV module from your distributor.



WARNING: The M215 may be paired only with a 60-cell PV module.

Electrical Compatibility

Model Number	Works with PV Module Type	PV Module Connector Type
M215-60-2LL-S22 M215-60-2LL-S22-NA	60-cell PV module WARNING: The M215 can be paired only with a 60-cell PV module.	MC-4 Type 2 Locking or Amphenol H4 Locking
M215-60-2LL-S23 M215-60-2LL-S23-NA		Tyco Solarlock Locking
M215-60-2LL-S24 M215-60-2LL-S24-NA		SMK

Branch Circuit Capacity

Plan your AC branch circuits to meet the following limits for maximum number of M215s per branch when protected with a 20-amp over-current protection device (OCPD).

Maximum number of M215s when protected with a 20 A OCPD	
Service type	Max M215s per AC branch circuit
Split phase 240 VAC	17
Three phase 208 VAC	25



Utility service requirements: The M215-60-2LL works with split phase 240 VAC service or with three phase 208 VAC service.

Parts and Tools Required

In addition to the microinverters, PV modules, and racking, you will need the following.

Enphase Equipment

- Enphase Envoy® Communications Gateway (optional, but recommended)



BEST PRACTICE: Connect the Envoy before the solar installation is complete.

When powered up and connected for the first time, the Envoy may retrieve an automatic upgrade from Enphase. Because this upgrade may take up to 20 minutes, connect the Envoy first (connect to both AC power and to the broadband router) so that it performs the upgrade well before the solar module installation is complete. For more information, see the *Envoy Communications Gateway Installation and Operation Manual*.

- Engage Cable, as needed. (See “Engage Cable Planning and Ordering Information” on page 30.)



NOTE: Order the correct Engage Cable type. Installers must order Engage Cable for either 240 VAC single phase, typical for residential applications, or 208 VAC three phase, typical for commercial installations. All drop connectors on the Engage Cable bear labels indicating the cable voltage designation.

- Cable clips
- Sealing caps, as needed (for any unused drops on the Engage Cable)
- Terminators, as needed (one needed at the end of each AC branch circuit)
- Enphase disconnect tool (number 2 and 3 Phillips screwdrivers can be substituted)

Other Items

- Outdoor-rated, weather-proof AC junction box(es)
- Gland or strain relief fitting (one per AC junction box)
- Continuous grounding conductor, grounding washers
- Number 2 and 3 Phillips screwdrivers
- Torque wrench, sockets, wrenches for mounting hardware
- Adjustable wrench or open-ended wrench (for terminators)
- Handheld mirror (to view LEDs on the undersides of the microinverters)

Lightning and Surge Suppression

Enphase Microinverters have integral surge protection, greater than most traditional inverters. However, if the surge has sufficient energy, the protection built into the microinverter can be exceeded, and the equipment can be damaged. For this reason, Enphase recommends that you protect your system with lightning and/or surge suppression devices. In addition to having some level of surge suppression, it is important to have insurance that protects against lightning and electrical surges.

Install these devices per vendor instructions.

Residential	Commercial
<ul style="list-style-type: none"> • Citel DS72-RS-120 surge protector; data sheet • Delta LA-302 lightning arrestor; website • Leviton 51110 or 51110-001; whole house surge protection panel; website • Midnight solar surge protection device MNSPD-300 or MNSPD-300FM (with flush mount box); website 	<ul style="list-style-type: none"> • Citel DS73-RS-G surge protector; data sheet • Delta LA-303 lightning arrestor; website

Enphase Microinverter Installation

Installing the Enphase Microinverter System involves several key steps. Each step listed here is detailed in the following pages. Follow the instructions in this section to install Enphase M215 Microinverters.

- Step 1:** Install the Envoy Communications Gateway
- Step 2:** Measure AC Voltage at the Electrical Utility Connection
- Step 3:** Install the AC Branch Circuit Junction Box
- Step 4:** Position the Enphase Engage Cable
- Step 5:** Attach the Microinverters to the PV Racking
- Step 6:** Ground the System
- Step 7:** Dress the Enphase Engage Cable
- Step 8:** Connect the Microinverters
- Step 9:** Terminate the Unused End of the Engage Cable
- Step 10:** Connect the Engage Cable to AC Junction Box(es)
- Step 11:** Complete the Installation Map
- Step 12:** Connect the PV Modules



DANGER: DO NOT connect or disconnect the PV module and Enphase Microinverter without first removing AC power from the PV system.

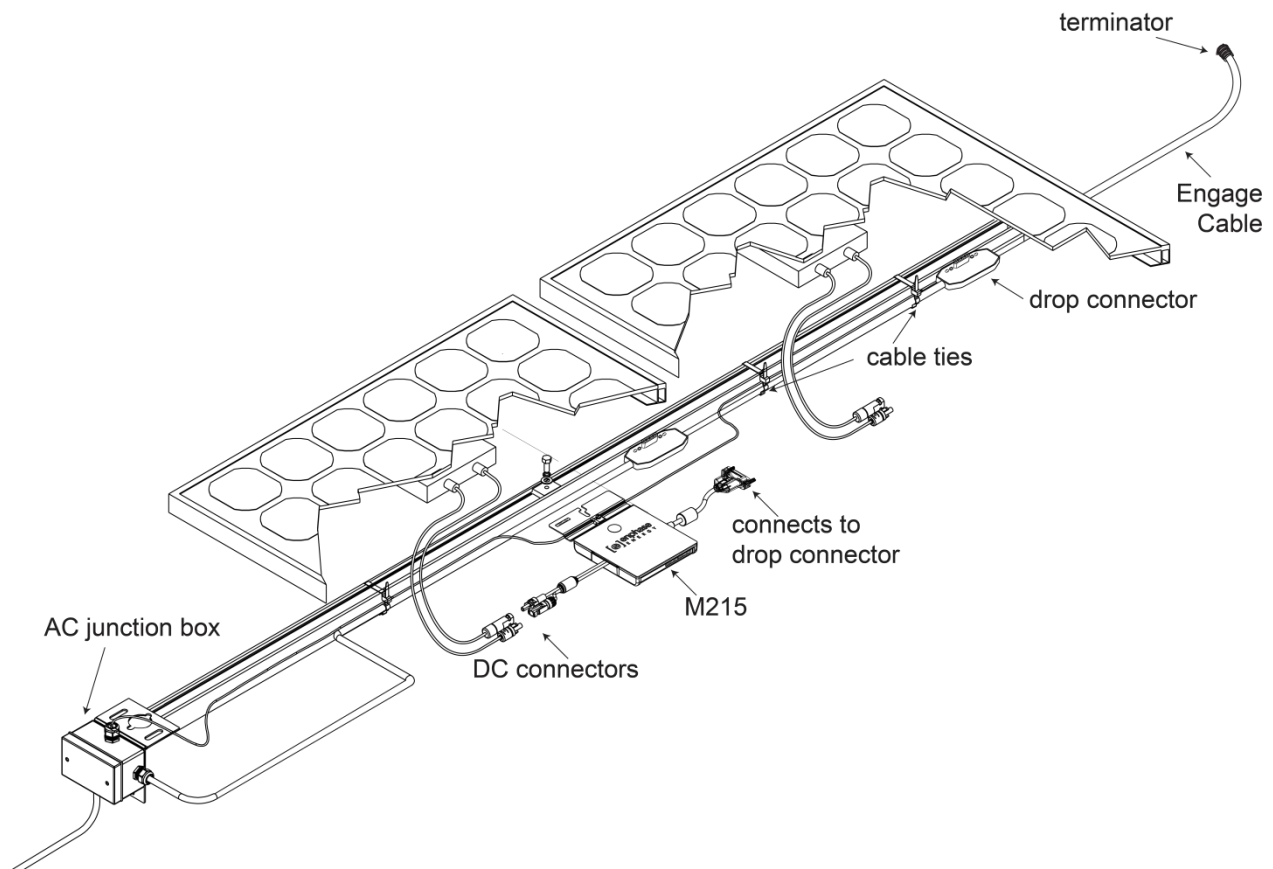

Step 1: Install the Envoy Communications Gateway

Install the Envoy by following the steps in the *Envoy Installation and Operation Manual*. You install the Envoy first to allow it to retrieve any available software upgrades before it can detect microinverters.



BEST PRACTICE: When powered up and connected for the first time, the Envoy may retrieve an automatic upgrade from Enphase. Because this upgrade may take up to 20 minutes, connect the Envoy first at the site (connect to both AC power and the broadband router) so that it performs the upgrade well before the solar module installation is complete.



WARNING! Do not remove power from the Envoy if the LCD displays: “Upgrading. . . Do Not Unplug.”

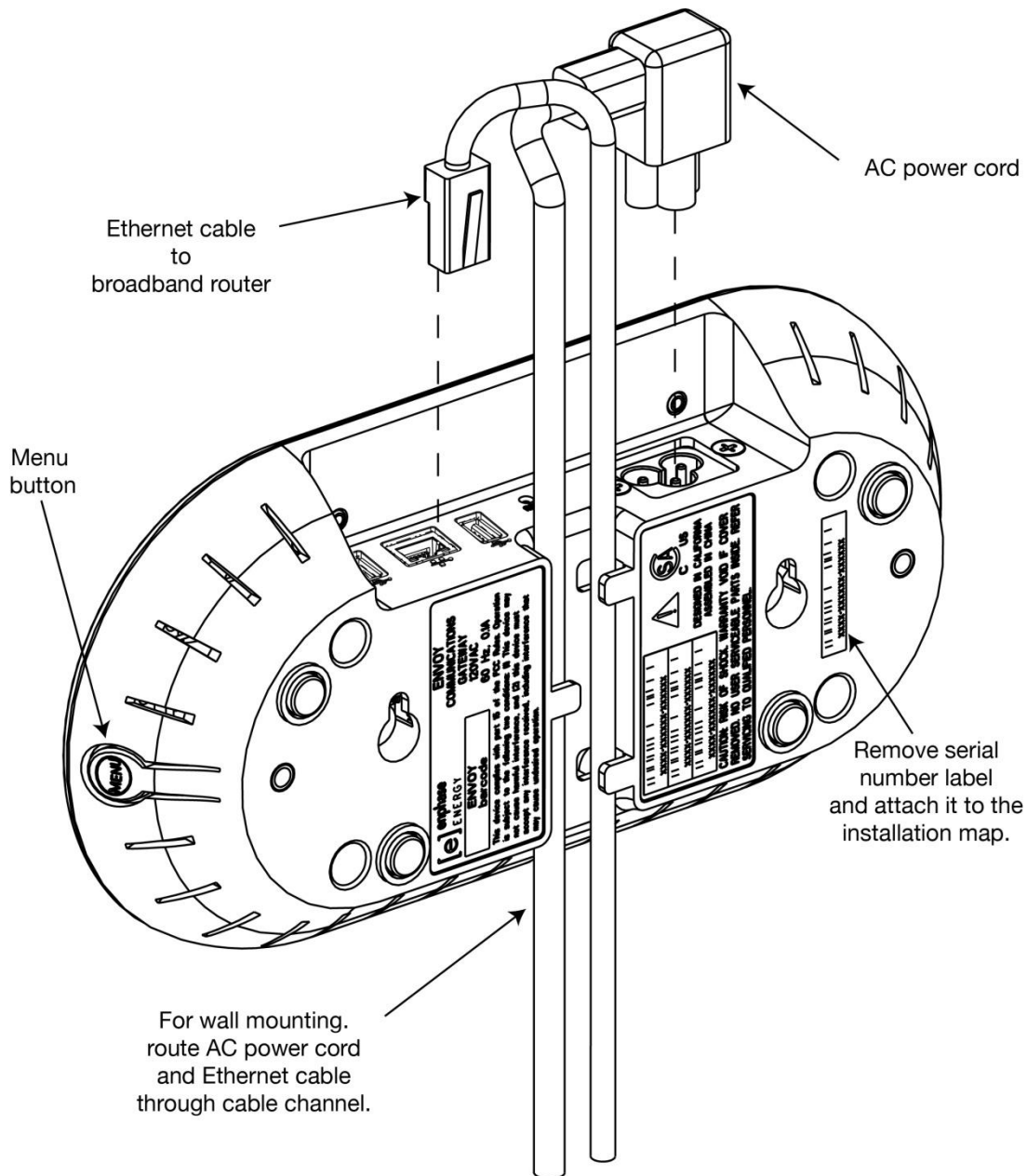

Step 2: Measure AC Voltage at the Electrical Utility Connection

Measure AC line voltage at the electrical utility connection to confirm that it is within range. Acceptable ranges are shown in the following table.

Single-phase 240 Volt AC	
L1 to L2	211 to 264 VAC
L1, L2 to neutral	106 to 132 VAC
Three-phase 208 Volt AC	
L1 to L2 to L3	183 to 229 VAC
L1, L2, L3 to neutral	106 to 132 VAC

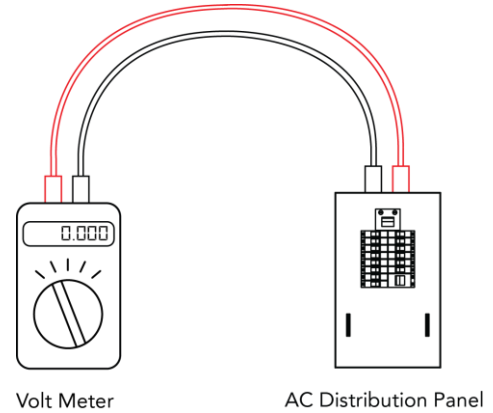

NOTE: Check the labels on the Engage Cable drop connectors to be sure that the cable matches the electrical utility service at the site. Use 208 VAC (208 VAC three-phase) Engage Cable at sites with three-phase 208 VAC service, or use 240 VAC Engage Cable at sites with 240 VAC single-phase service.

Step 3: Install the AC Branch Circuit Junction Box



DANGER: Risk of Electrical Shock. Be aware that installation of this equipment includes risk of electric shock. Do not install the AC junction box without first removing AC power from the Enphase System.



WARNING: Only use electrical system components approved for wet locations.



WARNING: Do NOT exceed the maximum number of microinverters in an AC branch circuit as listed on page 28 of this manual. You must protect each microinverter AC branch circuit with a 20 amp maximum breaker.

- a. Size the AC wire gauge to account for voltage rise. Select the correct wire size based on the distance from the beginning of the microinverter AC branch circuit to the breaker in the load center.

All components of system wiring must be considered, including internal voltage rise within the length of Engage Cable. Typically, three wire sections and several wire terminations must be quantified. There is also some resistance associated with each circuit breaker. As all of these resistances are in series, they add together. Since the same current is flowing through each resistance, the total voltage rise is total current times the total resistance. For a single-phase system, the total resistance is equal to two times the one-way resistance. For a three-phase system, each of the three line currents and resistances must be calculated.

Standard guidelines for voltage rise on feeder and AC branch circuit conductors might not be sufficient for microinverter AC branch circuits that contain the maximum allowable microinverters. This is due to high inherent voltage rise on the AC branch circuit.

For more information, refer to our Technical Brief, [Voltage Drop Considerations for M215](#).

- b. Install an appropriate junction box at a suitable location on the PV racking system. You can center feed the branch, or you can install the junction box at the end of a row of PV modules.



Best Practice: Center-feed the branch circuit to minimize voltage rise in a fully populated branch. This practice greatly reduces the voltage rise as compared with an end-fed branch. To center-feed a branch, divide the circuit into two sub-branch circuits protected by a single overcurrent protection device (OCPD).

- c. Provide an AC connection from the AC junction box back to the electrical utility connection using equipment and practices as required by the NEC and local jurisdictions.

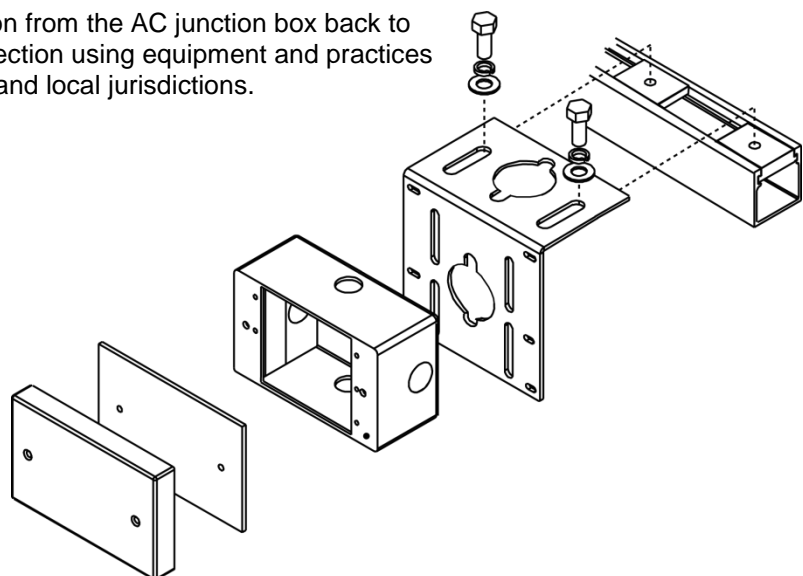

Step 4: Position the Enphase Engage Cable

The Engage Cable is a continuous length of 12 AWG (2.5 mm²), outdoor-rated cable with integrated connectors for microinverters. These connectors are preinstalled along the Engage Cable at intervals to accommodate PV module widths. The microinverters plug directly into the connectors, and the Engage Cable is terminated into the junction box that feeds electricity back to the system AC disconnect.



NOTE: Make sure you are using the correct cable type. Installers must order Engage Cable for either 240 VAC single phase, typical for residential applications or 208 VAC three phase, typical for commercial installations. All drop connectors on the Engage Cable bear labels indicating the cable type.

- a. Lay the Engage Cable along the route it will travel, positioning the connectors so that they align with the PV modules.



WARNING: Plan the AC branches so that they do not exceed the maximum number of microinverters in an AC branch circuit as listed on page 28 of this manual. You must protect each microinverter AC branch circuit with a 20 amp maximum breaker.

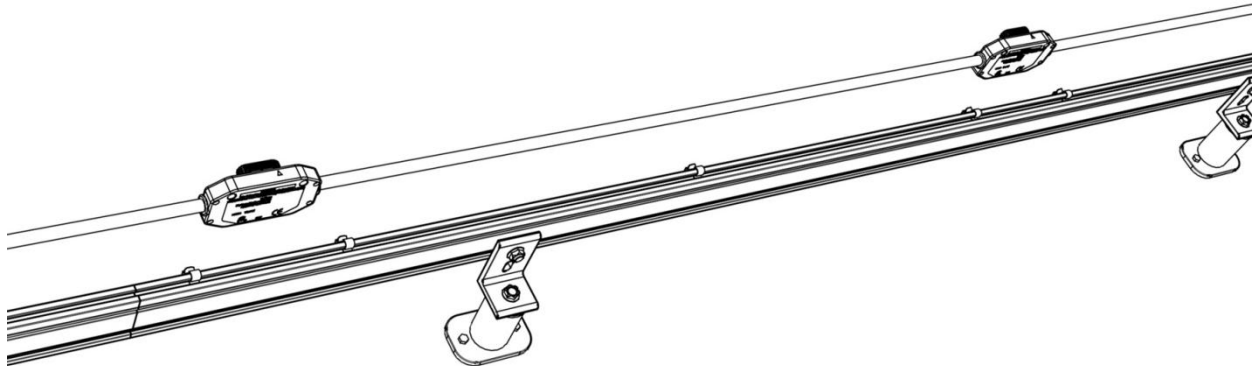

NOTE: Many PV modules have a central stiffening brace. In these cases, do **not** position the connector and microinverter at the exact center of the PV module. Instead, position the drop connectors so that the connectors do not conflict with the braces.

- b. PV module widths vary by manufacturer. On the Engage Cable, connectors are spaced at intervals to allow for the widest PV modules compatible with Enphase Microinverters. If narrower PV modules are used, it may be necessary to account for excess cable by looping the cable at suitable intervals.

Step 5: Attach the Microinverters to the PV Racking

- a. Mark the approximate centers of each PV module on the PV racking.
- b. Evaluate the location of the microinverter with respect to the PV module DC junction box or any other obstructions.
- c. Ensure that the microinverter does not interfere with the PV module frame or stiffening braces.
- d. Ensure that the connector from the microinverter can easily reach the connector on the Engage Cable.
- e. Allow a minimum of 1.9 cm (0.75 inches) between the roof and the bottom of the microinverter. Also allow 1.3 cm (0.50 inches) between the back of the PV module and the top of the microinverter.



WARNING: You must install the M215 under the module, out of rain and sun. Do not mount the microinverter in a position that allows long-term exposure to direct sunlight or in a vertical orientation that allows water to collect in the DC connector recess.

- f. Mount one microinverter at each location using suitable hardware. The indicator light on the underside of the microinverter will be facing the roof.



NOTE: Installing the microinverter black side up or vertically, with the DC connectors facing up, is not permitted.

- g. Torque the microinverter fasteners to the values shown. Do not over torque.
 - 6 mm (1/4") mounting hardware: 5 N m (45 to 50 in-lbs)
 - 8 mm (5/16") mounting hardware: 9 N m (80 to 85 in-lbs)



NOTE: Using a power screwdriver to tighten the mounting hardware is not recommended due to the risk of thread galling.

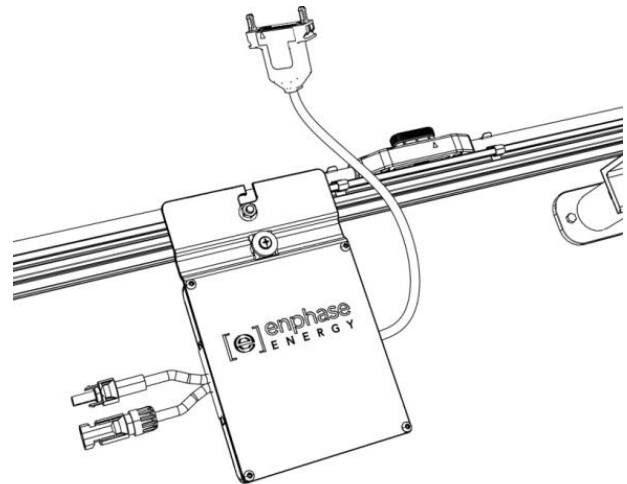

Step 6: Ground the System

Each M215 Microinverter comes with a grounding clip that can accommodate a 6-8 AWG GEC (grounding electrode conductor). Check local requirements for allowable grounding conductor sizes.



NOTE: Ground the system in accordance with all applicable local electrical codes and the National Electrical Code (NEC), ANSI/NFPA 70.



NOTE: CSA has evaluated and approved the Wiley Electronics “WEEB” grounding washers for use with the Enphase Microinverter. Compatible grounding washer part numbers and installation guidelines are included in the [Racking Compatibility List](#).



NOTE: The AC output neutral is not bonded to ground inside the microinverter.

- a. Route a continuous GEC through each of the microinverters to the NEC-approved AC grounding electrode.
- b. You can ground the PV racking and PV module to this conductor using a crimp (compression) connection.

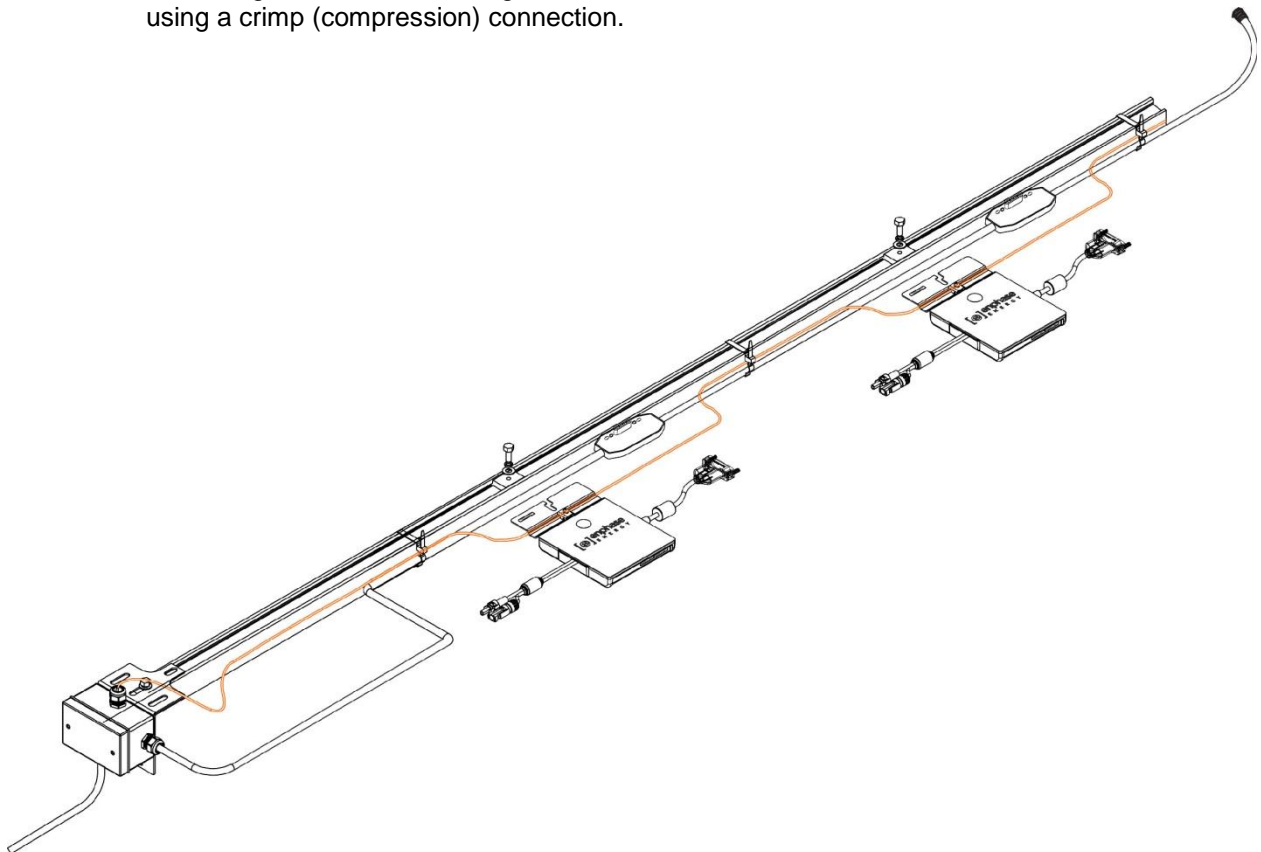

- c. Torque the 10/32 grounding cleat screw to 2 N m (20 to 25 in-lbs). Do not over torque.



NOTE: Using a power screwdriver to tighten the grounding clamp screw is not recommended due to the risk of thread galling.

Step 7: Dress the Engage Cable



NOTE: Adhere to the following requirements:

- Do not expose the connection to directed, pressurized liquid (water jets, etc.).
- Do not expose the connection to continuous immersion.
- Do not expose the AC connector to continuous tension (e.g., tension due to pulling or bending the cable near the connection)
- Use only the connectors and cables provided.
- Do not allow contamination or debris in the connectors.
- Use the cable and connectors only when all parts are present and intact.

- a. Attach the Engage Cable to the PV racking using the cable clips, or you may use tie wraps. The cable clips are designed so that the connector from the microinverter can also be dressed into the clip underneath the Engage Cable.

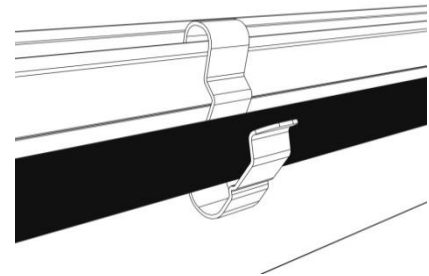

NOTE: There are two release-holes in the drop connector on the cable. These are **not** for mounting but are used to disconnect the connector. **Keep these release holes clear and accessible.**

- b. Dress any excess in loops so that the Engage Cable does **not** contact the roof.

There are several ways to support the cable. One method is to place tie wraps or clips on either side of the connector. Use one or two additional clips, tie wraps, or other support scheme to secure the cable between connectors.

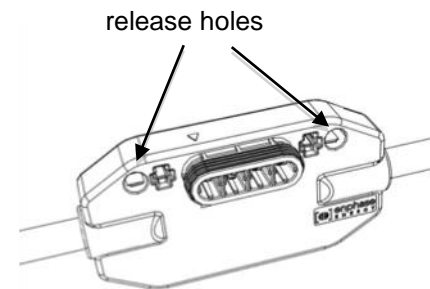

NOTE: When looping the Engage Cable, do not exceed the minimum bend radius of 4.75 inches (12 cm).



WARNING: Tripping Hazard. Loose cables can become a tripping hazard. Dress the Engage Cable to minimize this potential.

Step 8: Connect the Microinverters

- a. Remove and discard the temporary shipping caps from the Engage Cable and connect the microinverter. There are two latching mechanisms within the connectors. Listen for **two** clicks as the connectors engage. Ensure that **both** latching mechanisms have engaged.
- b. Repeat for all microinverters in the AC branch circuit.
- c. Cover any unused connector with a sealing cap. Listen for two clicks as the connectors engage. Ensure that **both** latching mechanisms have engaged.

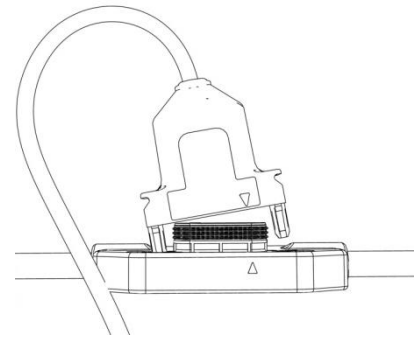

NOTES: Do not use the temporary shipping cap to cover unused connectors. The shipping cap does not provide an adequate environmental seal. Enphase sealing caps are required to protect against moisture ingress.

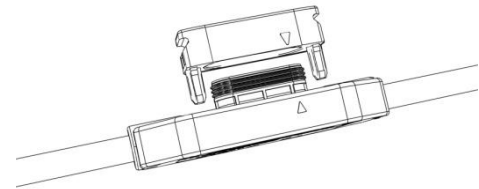

Enphase sealing caps are IP67 rated. Within the term “IP67”, “IP” indicates an Ingress Protection (IP) rating against dust and liquids. This specific rating of IP67 indicates that this connector protects against all dust particles and immersion in liquid.



WARNING: Make sure protective sealing caps have been installed on **all** unused AC connectors. Unused AC connectors are live when the system is energized by the utility system. **Sealing caps may not be reused.**



NOTE: If you need to remove a sealing cap, you must use the Enphase disconnect tool or a #3 Phillips screwdriver. See “Disconnect a Microinverter from the PV Module” on page 25. Sealing caps may not be reused.

Step 9: Terminate the Unused End of the Engage Cable



WARNING: Risk of Electrical Shock. The terminator cap must not be installed while power is connected.



NOTE: Adhere to the following requirements:

- Use the terminator only once. If you open the terminator following installation, the latching mechanism is destroyed. Do not reuse the terminator.
- If the latching mechanism is defective, do not use the terminator.
- Do not circumvent or manipulate the latching mechanism.
- Use the terminator and no other method to seal the conductor end of the trunk.
- Do not expose the terminator cap to directed, pressurized liquid (water jets, etc.).
- Do not expose the terminator to continuous immersion.
- Do not expose the terminator to continuous tension (e.g., tension due to pulling or bending the cable near the terminator)
- Do not install or use in potentially explosive environments.
- Do not allow the terminator to come into contact with open flame.
- Use the terminator cap assembly only when all parts are present and intact.
- Fit the terminator cap using only the prescribed tools.
- Make sure that all seals are seated correctly in the wire organizer.
- When stripping off the cable sheath, make sure that the conductors are not damaged. If the conductors are damaged, proper system function cannot be assured.

- a. Remove 60 mm (2.5 inches) of the cable sheath from the conductors.
- b. Slide the hex nut onto the Engage Cable.
- c. Insert the Engage Cable all the way into the wire organizer (up to the stop).
- d. Bend the individual wires back into the recesses in the wire organizer so that they angle back toward the cable.
- e. Cut the individual wires so that no excess extends outside of the wire organizer. The portions that angle back will need to extend enough to fit neatly into the 0.5 cm (0.2 in) recesses in the wire organizer and flush with the edge of the cap.
- f. Screw the hex nut onto the cap. **Never unscrew the hex nut** as this can twist and damage the cable.
- g. Hold the cap with an Enphase disconnect tool, or insert a #2 Phillips screwdriver.
- h. Use a 22 mm (7/8 inch) wrench to tighten the hex nut until the latching mechanism is screwed all the way to the base.
- i. Use a tie wrap or cable clip to attach the cable to the PV racking, so that the Engage Cable and terminator do not touch the roof.
- j. Ensure that all cabling is located underneath the PV module.

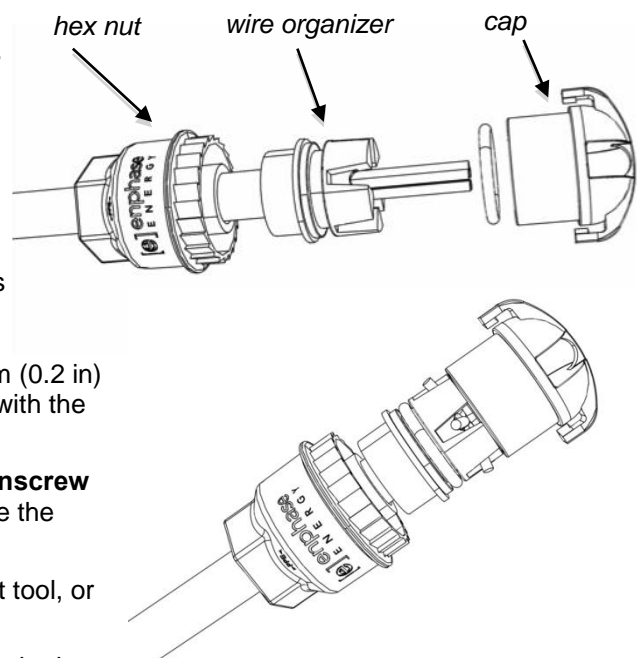

Step 10: Connect the Engage Cable to AC Junction Box(es)

- a. Connect Engage Cable into the AC branch circuit junction box using an appropriate gland or strain relief fitting. The Engage Cable requires a strain relief connector with an opening of 1.3 cm (0.5 inches) in diameter.
- b. Connect the Engage Cable into additional AC junction boxes as needed to transition to conduit between smaller sub-arrays.

Refer to the wiring diagrams located on page 34 for more information.

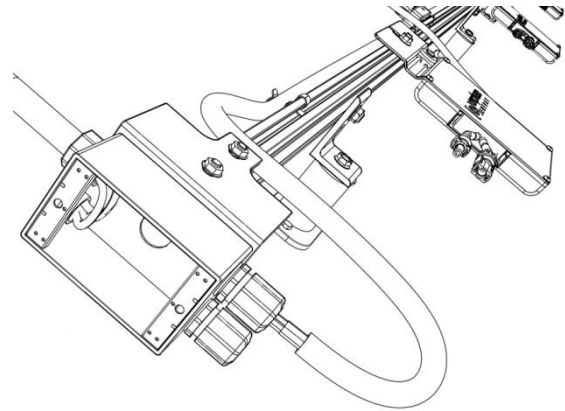

240 Volt AC Split Phase Wiring	208 Volt AC Three-Phase Wiring
Black: L1 Red: L2 White: Neutral Green: Ground	Black: L1 Red: L2 Blue: L3 White: Neutral Green: Ground



NOTE: The green wire acts as equipment ground (EGC). A continuous GEC for system ground is also required as described in “Step 6: Ground the System”.

Wires are identified as follows: L1 is sheathed in Black, L2 is sheathed in red, L3 is sheathed in blue, Neutral is sheathed in white, and Ground is sheathed in green. The grounding wire is used to ground the microinverters. A continuous ground is required in addition to this green grounding wire.

Balanced 208 VAC (three-phase) is accomplished by alternating phases between microinverters as shown:

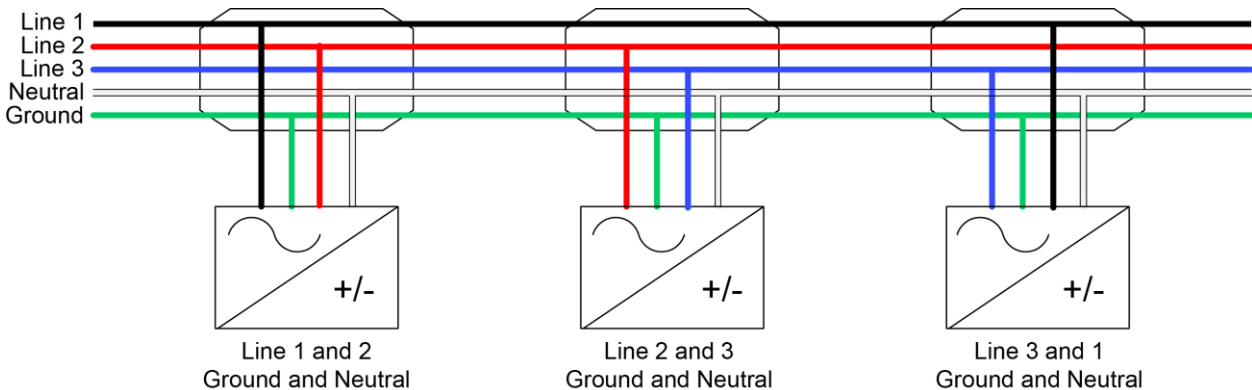

Step 11: Complete the Installation Map

The Enphase Installation Map is a diagrammatic representation of the physical location of each microinverter in your PV installation. You will create the virtual array in Enlighten from this map. Use the blank map on page 33 to record microinverter placement for the system, or provide your own layout if a larger or more intricate installation map is required.

You can build the system map manually, by peeling the serial number labels from the microinverters and placing the labels on the installation map, or you can use the ArrayGun feature from the Enphase Installer Toolkit to easily build and configure a system. Refer to <http://enphase.com/products/arraygun/> for more information.

To manually build the Installation Map:

- a. Each Enphase Microinverter has a removable serial number label located on the mounting plate. Peel the removable serial number label from each Enphase Microinverter and affix it to the respective location on the Enphase installation map (see map on page 33). Remember to keep a copy of the installation map for your records.
- b. Draw a top-down view of the array using the Array Map template. Make sure to leave enough room to place the serial number stickers.
- c. When installing the microinverters, remove the serial number labels located next to the DC input cables and place them in the correct order on your drawing of the system. Remember to keep a copy of the installation map for your records.

Step 12: Connect the PV Modules



NOTE: Completely install all microinverters and all system AC connections prior to installing the PV modules.

- a. Mount the PV modules above the microinverters.
- b. Mate the microinverters and PV modules as required. Repeat for all remaining PV modules using one microinverter for each PV module.



NOTE: The Status LED on the underside of each microinverter will blink green six times to indicate normal start-up operation approximately one minute after DC power is applied.



WARNING: The M215 can be paired only with a 60-cell PV module.

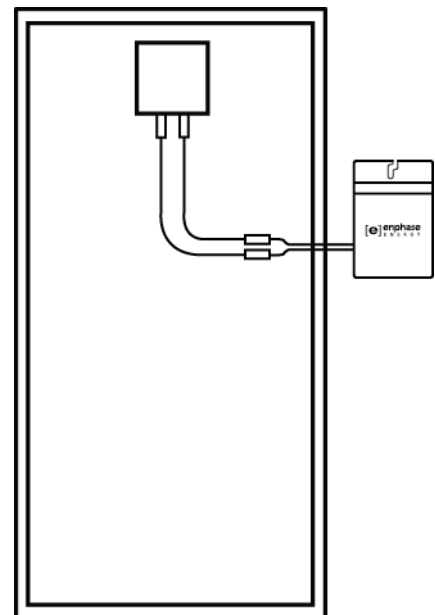

Commissioning and Operation



WARNING: Qualified personnel only may connect the Enphase Microinverter to the utility grid after receiving prior approval from the electrical utility company.



WARNING: Ensure that all AC and DC wiring is correct. Ensure that none of the AC and DC wires are pinched or damaged. Ensure that all AC junction boxes are properly closed.

Energize the System

1. Turn ON the AC disconnect or circuit breaker for each microinverter AC branch circuit.
2. Turn ON the main utility-grid AC circuit breaker. Your system starts producing power **after a five-minute wait** time.
3. The Enphase Microinverters begins communicating over the power lines to the Envoy. The time required for all microinverters to report to the Envoy varies with the number of microinverters in the system. The first units should be detected within 15 minutes but the entire system could take hours to detect.
4. The M215 has field-adjustable voltage and frequency trip points. If adjustments are required by your local utility, the installer can use the Envoy to Manage the Grid Profile after all microinverters have been detected.

Build the Virtual Array

When the system is energized and the Envoy detects at least one microinverter, create the virtual array in Enlighten from the installation map you created.

You can scan and upload the paper copy of the Installation Map, or you can use the ArrayGun feature from the Enphase Installer Toolkit to easily build and configure a system. Refer to <http://enphase.com/products/arraygun/> for more information.

To scan and upload the map and build the array:

1. Scan the installation map and upload it to the Activation form online.
2. Use Array Builder to create the virtual array in Enlighten. Use the installation map created in Installation step 10 as your reference.



NOTE: Go to <http://enphase.com/support/videos/> to view the Array Builder demo.

3. If you do not already have an account, go to <http://www.enphase.com> and click “Enlighten Login” to register.

Once the virtual array is built, Enlighten displays a graphic representation of the PV system. It also shows detailed current and historical performance information. Go to <http://www.enphase.com> for more information on the Enphase Enlighten web-based monitoring and analysis.

M215 Operation

The Enphase Microinverter is powered on when sufficient DC voltage from the PV module is applied. The Status LED of each microinverter will blink green six times to indicate normal start-up operation approximately one minute after DC power is applied. You may need to use a handheld mirror to view indicator lights on the undersides of the microinverters.

Troubleshooting

Adhere to all the safety measures described throughout this manual. Qualified personnel can use the following troubleshooting steps if the PV system does not operate correctly.



WARNING: Do not attempt to repair the Enphase Microinverter; it contains no user-serviceable parts. If the microinverter fails, contact Enphase customer service to obtain an RMA (return merchandise authorization) number and start the replacement process.

Status LED Indications and Error Reporting

Startup LED Operation:

The Status LED of each microinverter blinks green six times to indicate normal start-up operation approximately one minute after DC power is applied.

Six short red blinks after DC power is first applied to the microinverter indicate a failure during microinverter startup.



LED on underside of M215

Post-Startup LED Indications

Use a handheld mirror to view indicator lights on the undersides of the microinverters:

- **Flashing Green:** Indicates normal operation. The microinverter is receiving messages from the Envoy and senses that the utility grid is within voltage/frequency specifications.
- **Flashing Orange:** Indicates that the microinverter is not receiving messages from the Envoy, but is otherwise operating normally. The microinverter senses that the utility grid is within voltage/frequency specifications.
- **Flashing Red:** Indicates that the microinverter is **not operating normally**. The microinverter does not sense that the utility grid is within voltage/frequency specifications. The microinverter cannot produce power until this is resolved. See “Troubleshoot an Inoperable Microinverter” on page 23.
- **Solid Red:** GFDI fault. Troubleshoot as described in the following section.

GFDI Fault

A solid red status LED when DC power has been cycled indicates the microinverter has detected a ground fault (GFDI) error. The LED will remain red and the fault will continue to be reported by the Envoy until the error has been cleared.

The condition should clear with operator intervention unless conditions causing the event have not been remedied or if the failure is permanent.

Follow the instructions in the *Envoy Communications Gateway Installation and Operation Manual* at <http://www.enphase.com/support> to clear this condition. Or, for assistance, contact Enphase customer support at support@enphase.com.

Other Faults

All other faults are reported to the Envoy. Refer to the *Envoy Communications Gateway Installation and Operation Manual* at <http://www.enphase.com/support> for troubleshooting procedures.

Troubleshoot an Inoperable Microinverter

To troubleshoot an inoperable microinverter, follow the steps in the order shown.



WARNING: Be aware that only qualified personnel should troubleshoot the PV array or the Enphase Microinverter.



Best Practice: Never disconnect the DC wire connectors under load. Ensure that no current is flowing in the DC wires prior to disconnecting. If necessary, use an opaque covering to cover the PV module prior to disconnecting the PV module. Always disconnect AC power before disconnecting the PV module wires from the Enphase Microinverter. The AC connector of the microinverter is suitable as a disconnecting means.



WARNING: The AC and DC connectors on the cabling are rated as a disconnect only when used with an Enphase Microinverter.



WARNING: The Enphase Microinverters are powered by DC power from the PV modules. Make sure you disconnect the DC connections and reconnect DC power to watch for the six short LED blinks one minute after DC is applied.

1. Make sure AC breakers and disconnects are closed.
2. Check the connection to the utility grid and verify that the utility voltage are within allowable ranges shown in the Technical Data section on page 27 of this manual.
3. Verify that AC line voltage at all solar power circuit breakers at the load center and subpanels is within the ranges shown in the following table.
4. Verify that AC line voltage at the junction box for each AC branch circuit are within the ranges are shown in the following table:

240 Volt AC, Split Phase		208 Volt AC, Three Phase	
L1 to L2	211 to 264 VAC	L1 to L2 to L3	183 to 229 VAC
L1, L2 to neutral	106 to 132 VAC	L1, L2, L3 to neutral	106 to 132 VAC

5. Using an Enphase disconnect tool, disconnect the AC cable for the microinverter in question from the Engage Cable.
6. Verify that utility power is present at the microinverter by measuring line to line and line to neutral at the Engage Cable connector.
7. Visually check that the AC branch circuit connections (Engage Cable and AC connections) are properly seated. Reseat if necessary. Check also for damage, such as rodent damage.
8. Make sure that any upstream AC disconnects, as well as the dedicated circuit breakers for each AC branch circuit, are functioning properly and are closed.
9. Disconnect and re-connect the DC PV module connectors. The Status LED of each microinverter will blink green six times to indicate normal start-up operation soon (less than one minute) after DC power is applied. The LED subsequently resumes normal operation if the Grid is present. See page 22 for normal LED operation.
10. Attach an ammeter clamp to one conductor of the DC cables from the PV module to measure microinverter current. This will be under one Amp if AC is disconnected.

- 11.** Verify the PV module DC voltage is within the allowable range shown in the Technical Data section on page 27 of this manual.
- 12.** Swap DC leads with a known good, adjacent PV module. If after checking Enlighten periodically (this may take up to 30 minutes), the problem moves to the adjacent module, this indicates that the PV module isn't functioning correctly. If it stays in place, the problem is with the microinverter. Call Enphase Customer Support for help in reading the microinverter data and for help in obtaining a replacement microinverter, if needed.
- 13.** Check the DC connections between the microinverter and the PV module. The connection may need to be tightened or reseated. If the connection is worn or damaged, it may need replacement.
- 14.** Verify with your utility that line frequency is within range.
- 15.** If the problem persists, contact Customer Support at support@enphase.com.

Disconnect a Microinverter from the PV Module

If problems remain after following the troubleshooting steps listed previously, contact Enphase at support@enphaseenergy.com. If Enphase authorizes a replacement, follow the steps below. To ensure the microinverter is not disconnected from the PV modules under load, adhere to the following disconnection steps in the order shown:

1. De-energize the AC branch circuit breaker.
2. Disconnect the microinverter from the Engage Cable as follows:

Enphase AC connectors are tool-removable only. To disconnect an M215 from the Engage Cable, insert the two large prongs of the disconnect tool (see illustration) into the two holes in the drop connector. Rock the connector back and forth while pulling gently to disengage.

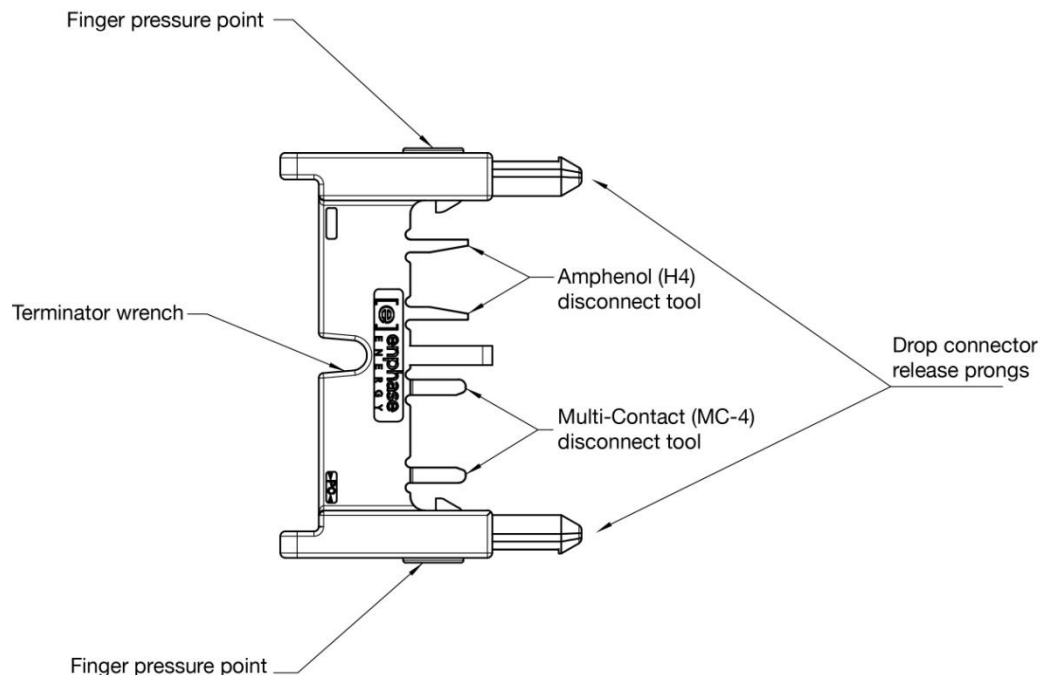

If the disconnect tool is not available, insert a #3 Phillips screwdriver into one hole, and rock that side of the drop connector out. Then, insert the screwdriver into the other hole and pull the connector out entirely.

3. Cover the PV module with an opaque cover.
4. Using a clamp on meter, verify there is no current flowing in the DC wires between the PV module and the microinverter.



NOTE: Take care when measuring DC current, as most clamp-on meters must be zeroed first and tend to drift with time.

5. Disconnect the PV module DC wire connectors from the microinverter using the Enphase disconnect tool.
6. Loosen the ground cleat screw and remove the grounding electrode conductor.
7. Remove the microinverter from the PV racking.



WARNING: Do not leave AC connectors on the Engage Cable uncovered for an extended period. If you do not plan to replace the microinverter immediately, you must cover any unused connector with a sealing cap. Sealing caps may not be reused.

Install a Replacement Microinverter

If Enphase authorizes a replacement (RMA), replace the microinverter as follows:

1. When the replacement M215 is available, verify that the AC branch circuit breaker is de-energized.
2. Attach the replacement microinverter to the PV racking using hardware recommended by your PV racking vendor.



WARNING: You must install the M215 under the module, out of rain and sun. Do not mount the microinverter in a position that allows long-term exposure to direct sunlight or in a vertical orientation that allows water to collect in the DC connector recess.



NOTE: Installing the microinverter black side up or vertically, with the DC connectors facing up, is not permitted.

3. Torque the microinverter fasteners to the values shown. Do not over torque.
 - 6 mm (1/4") mounting hardware: 5 N m (45 to 50 in-lbs)
 - 8 mm (5/16") mounting hardware: 9 N m (80 to 85 in-lbs)



NOTE: Using a power screwdriver to tighten the fasteners is not recommended due to the risk of thread galling.

4. If you are using grounding washers (e.g., WEEB), the old grounding washer should be discarded, and a new grounding washer must be used when installing the replacement microinverter.
5. Attach the grounding electrode conductor to the microinverter ground cleat. Torque the 10/32 grounding cleat screw to 2 N m (20 to 25 in-lbs). Do not over torque.



NOTE: Using a power screwdriver to tighten the grounding clamp screw is not recommended due to the risk of thread galling.

6. Connect the microinverter to the Engage Cable drop connector. There are two latching mechanisms within the connectors. Listen for two clicks as the connectors engage. Ensure that **both** latching mechanisms have engaged.
7. Mount the PV module above the microinverter.
8. Mate the microinverter and PV module as required.
9. Energize the AC branch circuit breaker, and verify operation of the replacement microinverter by checking the indicator light on the underside of the microinverter. You may need a handheld mirror to see the indicator light.
10. Initiate a device scan at the Envoy. To do this, press and hold the Menu button on the Envoy for two seconds to bring up the Envoy menu on the LCD window. When the LCD window displays "Enable Device Scan", release the Menu button.
This starts a 30-minute scan at the Envoy to discover the new microinverter.
11. Use Enlighten's Array Builder function to add the newly detected microinverter to the virtual array.
12. Ship the old microinverter to Enphase using the supplied return-shipping label.

Technical Data

Technical Considerations

The Enphase M215 Microinverters are electrically compatible with most 60-cell PV modules. Be sure to verify the voltage and current specifications of your PV module match those of the microinverter. For more information, refer to our list of compatible PV modules at <http://www.enphase.com/support>.



WARNING: You must match the DC operating voltage range of the PV module with the allowable input voltage range of the Enphase Microinverter.



WARNING: The maximum open circuit voltage of the PV module must not exceed the specified maximum input voltage of the Enphase Microinverter.

The output voltage and current of the PV module depends on the quantity, size and temperature of the PV cells, as well as the insolation on each cell. The highest PV module output voltage occurs when the temperature of the cells is the lowest and the PV module is at open circuit (not operating). The maximum short circuit current rating of the PV module must be equal to or less than the maximum input DC short circuit current rating of the microinverter.

M215 Specifications

Enphase M215 Microinverter Parameters				
Topic	Unit	Min	Typical	Max
DC Parameters				
MPPT voltage range	V	22		36
Operating range	V	16		36
Maximum DC input voltage	V			45
Minimum / Maximum start voltage	V	22		45
Maximum DC input short circuit current	A			15
Maximum DC input current	A			10.5
Ground fault protection	mA			1000
Maximum input source backfeed current to input source	A			0

Enphase M215 Microinverter Parameters				
Topic	Unit	Min	Typical	Max
AC Parameters				
Rated (continuous) AC output Power (-40 to +65°C)	W	215		
Output power factor		0.95	0.99	1
Nominal AC output voltage range				
240 VAC (split phase)	Vrms	211	240	264
208 VAC (three phase)	Vrms	183	208	229
Extended AC output voltage range				
240 VAC (split phase)	Vrms	206		269
208 VAC (three phase)	Vrms	179		232
Maximum AC output current at nominal voltage				
240 VAC (split phase)	Arms		0.9	
208 VAC (three phase)	Arms		1.0	
Nominal AC output frequency range	Hz	59.3	60	60.5
Extended AC output frequency range	Hz	57	60	60.5
Maximum AC output over current protection device	A	20		
Maximum AC output fault current & duration	Arms/cycles	1.05 Arms over 3 cycles 1.04 Arms over 5 cycles		
High AC Voltage trip limit accuracy	%	±2.5		
Low AC Voltage trip limit accuracy	%	±4.0		
Frequency trip limit accuracy	Hz	±0.1		
Trip time accuracy	ms	±33		
Miscellaneous Parameters				
Maximum inverters per 20 amp AC branch circuit				
240 VAC (split phase)				17
208 VAC (three phase)				25
Peak inverter efficiency	%	96.3		
CEC weighted efficiency	%	96.0		
Static MPPT efficiency (weighted, ref EN 50530)	%	99.6		
Total Harmonic Distortion	%		3.0	5
Operating temperature range (internal)	°C	-40		85
Ambient temperature range	°C	-40		65
Night Tare Loss	mW		46	
Storage temperature range	°C	-40		65

Enphase M215 Microinverter Parameters				
Topic	Unit	Min	Typical	Max
Features and Specifications				
Compatibility	Pairs with most 60-cell PV modules			
Dimensions not including mounting bracket (approximate)	17.3 cm x 16.4 cm x 2.5 cm (6.8" x 6.45" x 1.0")			
Weight	3.5 Lbs (1.6 Kg)			
Enclosure environmental rating	NEMA 6			
Torque specifications for fasteners (Do not over torque.)	<ul style="list-style-type: none"> 6 mm (1/4") mounting hardware: 5 N m (45 to 50 in-lbs) 8 mm (5/16") mounting hardware: 9 N m (80 to 85 in-lbs) 			
Torque specification for 10/32 ground cleat (Do not over torque.)	2 N m (20 to 25 in-lbs)			
Cooling	Natural convection: no fans			
Communication	Power line			
Standard warranty term	http://enphase.com/warranty			
Compliance	UL1741, IEEE1547, FCC Part 15 Class B CAN/CSA-C22.2 NO. 0-M91, 0.4-04, and 107.1-01			
Integrated DC disconnect	The DC connector has been evaluated and approved for use as the load-break disconnect required by the NEC.			
Integrated AC disconnect	The AC connector has been evaluated and approved for use as the load-break disconnect required by the NEC.			

Engage Cable Specifications

Specification	Value
System temperature range (ambient)	-40°C to +65°C (-40°F to 149°F)
Cable temperature rating	90°C Dry / 90°C Wet
Cable type	TC-ER
Cable conductor insulator rating	THWN-2
Environmental protection rating	IEC 60529 IP67
UV exposure rating: terminator, engage coupler, and drop connector body	UL 746 C, F1
Sunlight resistance (cable)	UL 1277
Compliance	UL486A/B, UL 514C, UL6703, UL 9703, IEC 60529 IP67, CAN/CSA 22.2 No. 21, 182.3
Conductor size	12 AWG
Cable diameter	1.25 cm (0.49")
Minimum bend radius	4.75 inches (12 cm)
Drop connector dimensions	11.8 cm x 6.0 cm x 3.2 cm (4.64" x 2.36" x 1.25")
Terminator cap dimensions	3.6 cm diameter x 5.1 cm tall (1.4" x 2")

Engage Cable Planning and Ordering Information

The Engage Cable is a continuous length of 2.5 mm² (12 AWG), outdoor-rated cable with integrated connectors for microinverters. These connectors are preinstalled along the Engage Cable at intervals to accommodate PV module widths. The microinverters plug directly into the cable connectors.

The cabling is compatible with a variety of PV racking systems. For a list of approved PV racking systems, refer to the PV Racking Compatibility document on the Enphase website (<http://www.enphase.com/support>).

Selecting Cable Type

Enphase Engage Cable is available in two different voltage types and two connector spacing options. Depending upon installer needs, the cable is also available in different lengths.

Connector Spacing Options

The gap between connectors on the cable can be either 1.025 meters (40") or 1.7 meters (67"). The 1.025 meter spacing is best suited for connecting PV modules installed in portrait orientation, while the 1.7 meter gap is best suited to PV modules installed in landscape orientation.

Cabling with connectors spaced at 1.025 meter (40") for PV modules in portrait orientation

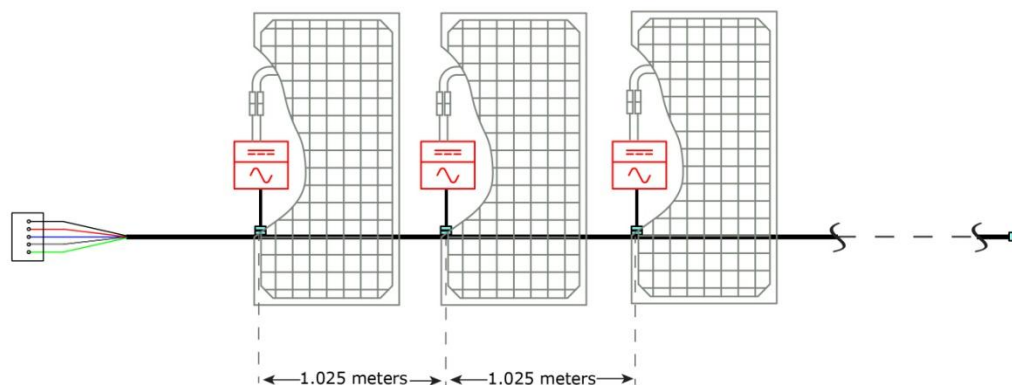

Cabling with connectors spaced at 1.7 meters (67") for PV modules in landscape orientation

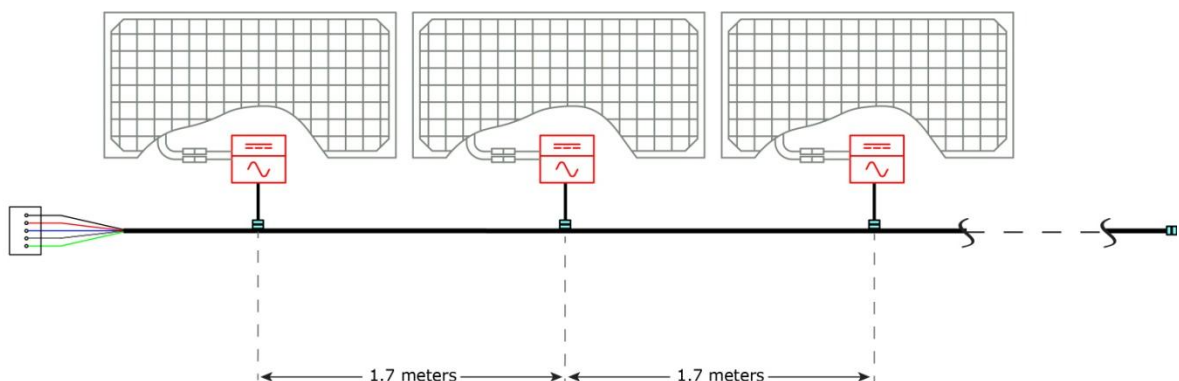

Voltage Types and Conductor Count

The voltage types are either 240 VAC split phase or 208 VAC three phase. **All cable connectors bear labels indicating their cable voltage designation.** Typically used for residential applications, 240VAC includes four conductors. Three-phase 208 VAC cabling includes five conductors, and is used for most commercial installations. Because Enphase microinverters output onto two phases, three phase cabling balances the phases by rotating conductor use from one microinverter to the next as shown on page 19.

Racking Compatibility

Engage Cabling is compatible with a variety of racking systems. For a list of approved PV module racking types, refer to the Racking Compatibility document at (<http://www.enphase.com/support>).

Cabling Length Options

Engage Cabling is available in shorter lengths with 30-40 connectors, depending upon voltage type. Longer lengths can be ordered and cut to suit per order. Ordering options include:

Model Number	Voltage type/ conductor #	Connector count	Connector spacing	PV module orientation	Approx. weight
ET10-240-40	240 VAC, 4 conductor	40	1.025 m (40")	Portrait	18.1 kg (40 lbs)
ET17-240-40	240 VAC, 4 conductor	40	1.7 m (67")	Landscape	20.4 kg (45 lbs)
ET10-208-30	208 VAC, 5 conductor	30	1.025 m (40")	Portrait	13.6 kg (30 lbs)
ET17-208-30	208 VAC, 5 conductor	30	1.7 m (67")	Landscape	15.9 kg (35 lbs)
ET10-240-BULK	240 VAC, 4 conductor	240	1.025 m (40")	Portrait	over 90 kg (200 lbs)
ET17-240-BULK	240 VAC, 4 conductor	240	1.7 m (67")	Landscape	over 90 kg (200 lbs)
ET10-208-BULK	208 VAC, 5 conductor	240	1.025 m (40")	Portrait	over 90 kg (200 lbs)
ET17-208-BULK	208 VAC, 5 conductor	240	1.7 m (67")	Landscape	over 90 kg (200 lbs)

Planning for Cable Lengths and Type

The Cabling System is flexible enough to adapt to almost any solar design. To determine the length and cable type that you need, take into account the following considerations:

- **The number of Enphase Microinverters to be installed on the AC branch circuit.** Be certain to allocate the correct number of connectors, including extra connectors for gaps and turns.
- **Additional length required to reach from the AC branch circuit junction box to the first microinverter.** If greater than half a connector interval is needed, it may be necessary to allow for one (or more) unused connectors in order to span this distance. Unused connectors must be covered with Enphase watertight sealing caps.
- Plan to **minimize the number of unused connectors** with three-phase systems. When cable connectors are left unused on a three-phase system, it creates a phase imbalance on

the branch circuit. If multiple cable connectors are skipped over multiple branch circuits, the imbalance can multiply.

- **Additional length required to reach from one row of PV modules to the next.** If the PV modules are laid out in multiple rows, the distance from one row to the next often requires additional cabling length.
- **Bend radius.** When planning cabling turns or loops, you must account for a minimum bend radius of 4.75 inches (12 cm).
- **Multiple sub-arrays.** Often, the AC branch circuit may be composed of several smaller sub-arrays across more than one roof plane. In this case, the cable is cut to service each smaller array, and the sub-arrays are connected together using appropriately rated lengths of conduit. The transition from cable to conduit is accomplished using an outdoor-rated AC junction box, as required by the NEC and local code. Unused connectors must be covered with Enphase watertight sealing caps.
- **Mixture of PV modules in both portrait and landscape orientation.** When PV modules are installed in mixed orientation (both portrait and landscape orientation), there are three choices for cabling:
 1. Cabling with 1.025 meter spacing between connectors results in cleanest install for the PV modules in portrait orientation. For PV modules placed in landscape orientation, plan for an unused connector between each PV module to accommodate the additional distance. Unused connectors must be covered with Enphase watertight sealing caps.
 2. Cabling with 1.7 meter spacing between connectors results in cleanest install for PV modules in landscape orientation, but requires that any additional cable length between PV modules in portrait orientation be coiled and dressed so that the cable does not contact the roof. Again, unused connectors must be covered with Enphase watertight sealing caps.
 3. Another solution when PV modules are installed in mixed orientation is to transition between 1.025 and 1.7-meter spacing cable options using the Engage Coupler or an outdoor-rated junction box. This junction box can be installed to the PV racking. Refer to <http://enphase.com/products/engage-coupler/> for information on the Engage Coupler.

Enphase Installation Map

	1	2	3	4	5	6	7
Panel Group: Azimuth: Tilt: sheet ____ of ____							
Customer information: To Sheet: _____ →							
Installer information: To Sheet: _____ →							
N S E W (circle one) <div style="text-align: center;"> </div>							
A							
B							
C							
D							
E							
F							
G							
H							
J							
K							
L							
M							

Scan completed map and upload it to Enphase. Click "Add New Activation" at www.enlighten.enphaseenergy.com. Use this map to build the virtual array in Enlighten's Array Builder.

Envoy Serial Label

DOCUMENT NUMBER: 140-00003
REGION: 04

M215 Dimensions

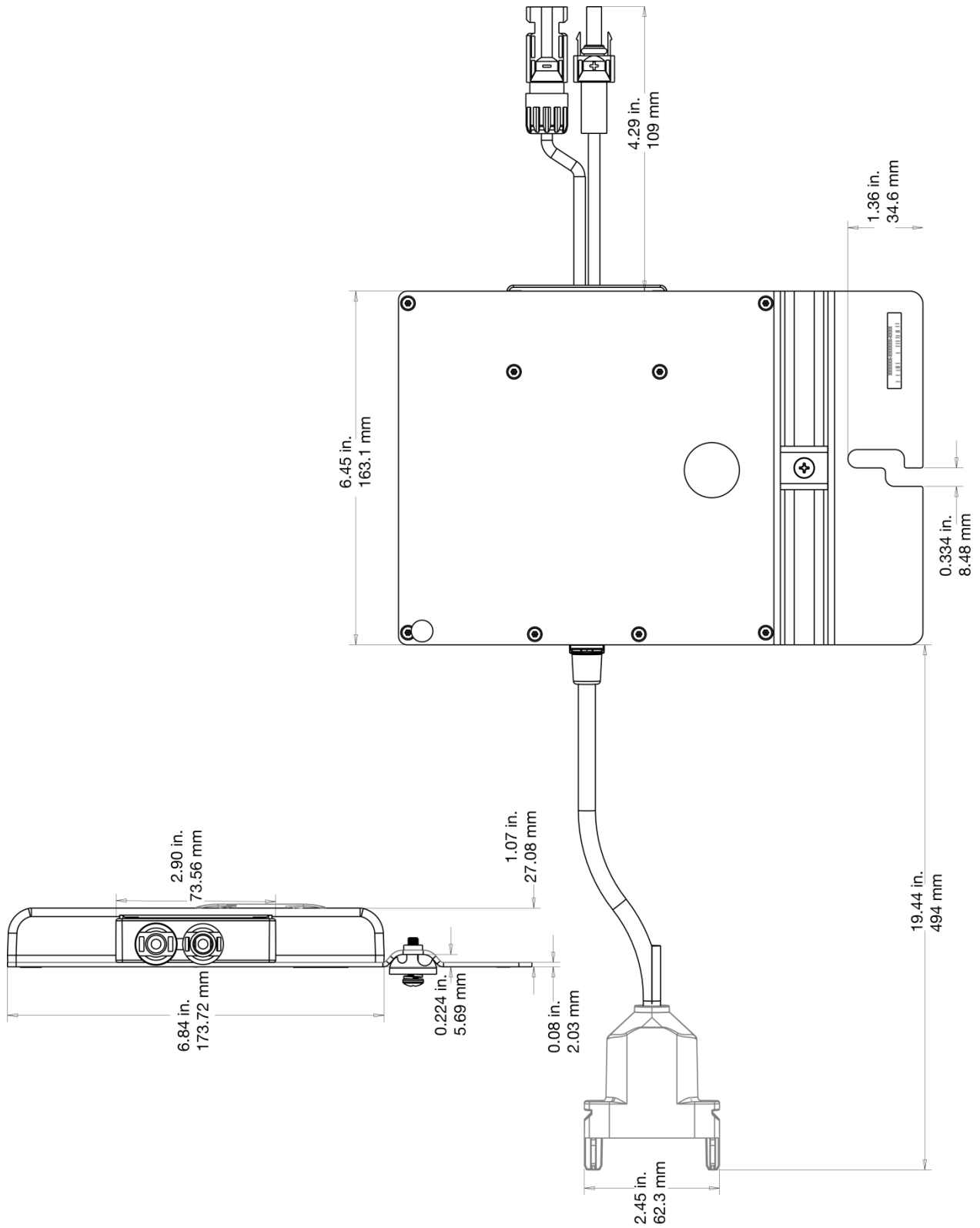

Sample Wiring Diagram: M215, 240 VAC

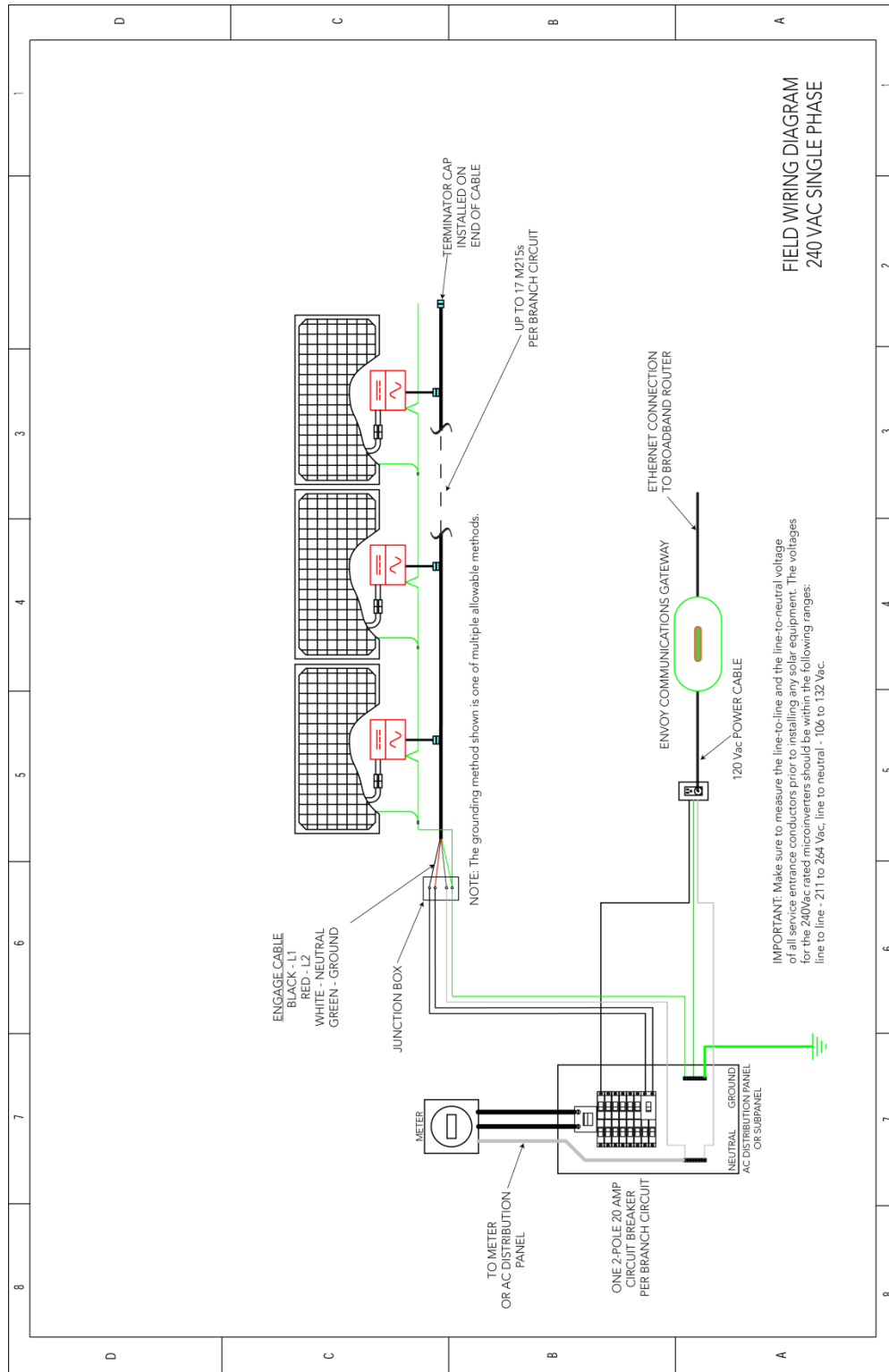

Sample Wiring Diagram: M215, 208 VAC

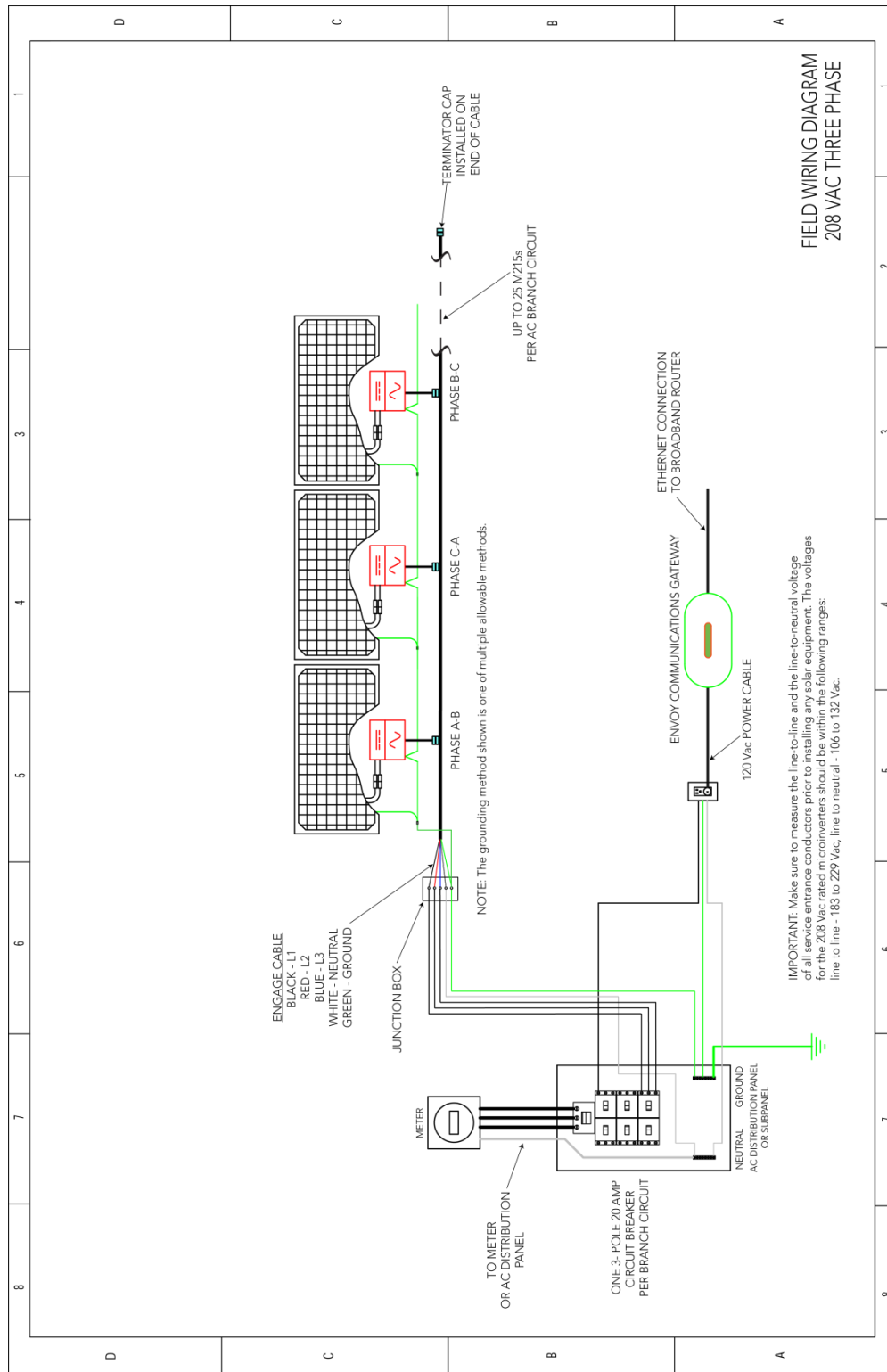

Enphase Energy Inc.

1420 N. McDowell Boulevard

Petaluma, CA 94954

www.enphase.com

info@enphaseenergy.com

support@enphaseenergy.com